

Molla di poliuretano / Polyuretane stripper

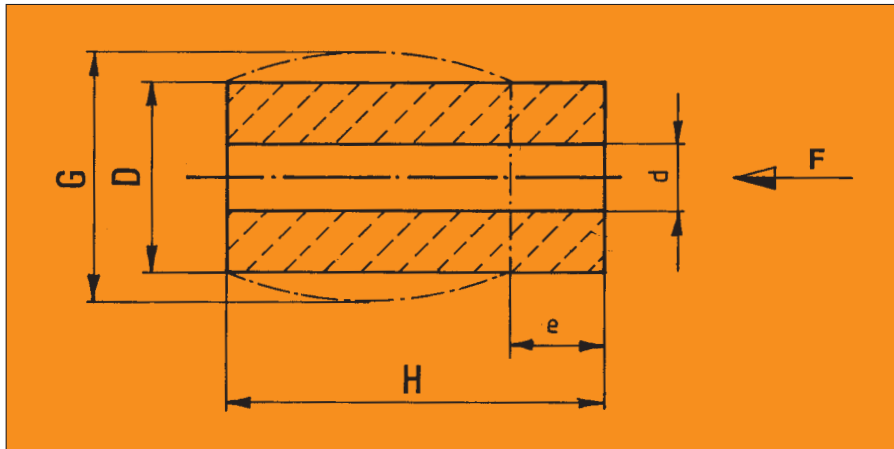

EMP - 1

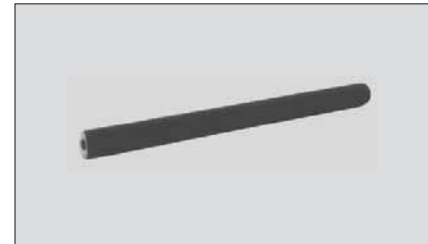

D = diametro esterno/external diameter
 d = diametro del foro/diameter of the hole
 H = altezza libera/free height

G = diametro max di gonfiamento/max. diameter of increase
 e = freccia max di compressione/max. compression arrow
 F = carico massimo/maximum charge

Sigla Courbhane Courbhane mark	80	90	95
Durezza Shore Shore hardness	80	90	95
Schiacciamento max Max. compression	33%	25%	20%

Ø Molla/Spring Ø	Diametro massimo di gonfiamento G/Maximum diameter of G increase									
	16	20	25	32	40	50	63	80	100	125
Durezza/Hardness 80	21	27	34	44	55	67	82	106	128	156
Durezza/Hardness 90	20	26	32	40	50	63	80	104	125	150
Durezza/Hardness 95	19	25	30	39	49	60	76	100	122	148
d	6,5	8,5	10,5	13,5	13,5	17	17	21	21	27
H	500	500	500	500	500	500	500	500	500	500

Esempio di ordinativo: D x Durezza